

GENERALLY WATER METER TO BE PLACED IN CCENTER OF LOT. (NOT IN DRIVEWAY OR SIDEWALK) EXCEPT ON TWIN HOME LOTS. (SEE NOTES)

NATURAL GROUND AROUND METER BOX

CAST IRON METER RING & LID (AUTO READ) 2" HOLE

DISTANCE VARIES 15' ON HIGH SIDE OF ROAD (TYP.)

WATER MAIN
PIPE SADDLE

SIDEWALK

PARKSTRIP

CURB AND GUTTER

1" MIN. POLY SERVICE LATERAL FROM MAIN (SEE NOTES)
(1-1/2" MIN. FOR TWIN HOME LOTS)

METER SIZE	BOX DIAMETER	D&L RING & COVER, OAE	FORD SETTER, OAE
1"	18"	L-2241	VBHC 74-18W-44-44-G or Q
1 1/2"	24"	B-5074	VBHH 76-18-44-66-G or Q
2"	30"	B-5076	VBHH 77-18-44-77-G or Q

1

1"-2" WATER METER-PLAN VIEW

SCALE: NONE

PROJECT # SU1037 DATE 07/12/2022

W-05A

CICWCD
STANDARD DETAILS
1"-2" WATER METER- PLAN VIEW
IRON COUNTY, UTAH



CICWCD
88 E Fiddlers Canyon Rd. Suite 220
Cedar City, Utah 84721
Phone 435-865-9901
Fax 435-865-9902

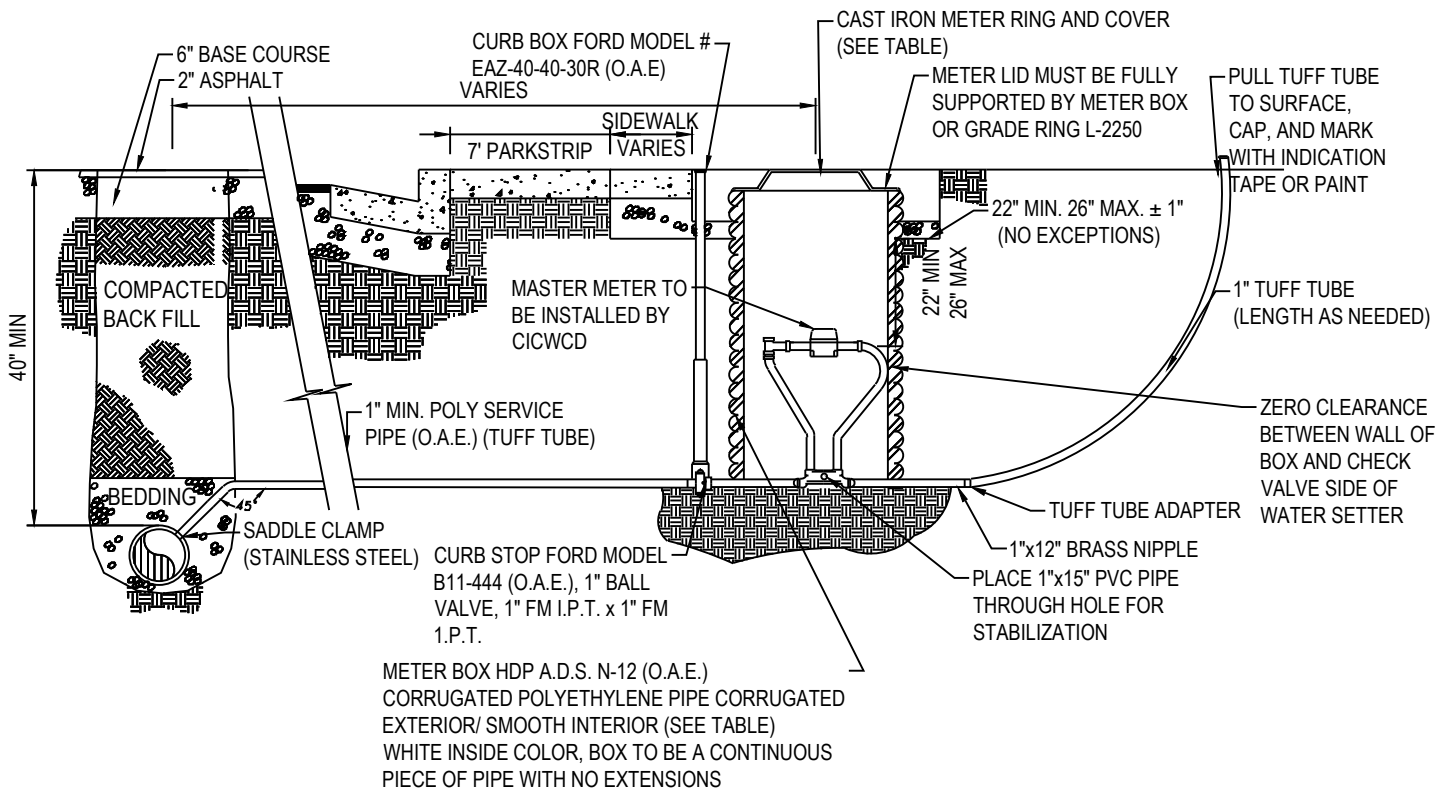

NOTES:

- 1- 3/4" LATERAL ALLOWED ONLY BY APPROVAL OF THE DISTRICT ENGINEER
- 2- ON TWIN HOME LOTS THE WATER METERS SHALL BE TEED OFF A COMMON 1-1/2" MIN. LATERAL COMING FROM THE MAIN AND PLACED ON EACH SIDE THE LOT DIVIDING LINE ACCORDING TO THE LAYOUT OF THE HOMES.

1 3/4"-2" WATER METER-PROFILE VIEW

SCALE: NONE

PROJECT # DATE
SU1037 07/12/2022

W-05B

CICWCD
STANDARD DETAILS
3/4"-2" WATER METER-PROFILE VIEW
IRON COUNTY, UTAH



CICWCD
88 E Fiddlers Canyon Rd. Suite 220
Cedar City, Utah 84721
Phone 435-865-9901
Fax 435-865-9902